

## Digital Laser Doppler Vibrometer Fiber-Series



### SWIR Fibre-Optic Laser Vibrometer

Infrared laser Doppler vibrometer with compact fibre-coupled measuring head. Ideal for confined spaces, in climatic chambers, or when exposed to high levels of radiation.



#### IDEAL FOR

- Dark / rough surfaces
- Where physical access is difficult
- Measurements in vacuum- or climatic chambers
- Quality inspection from different points of view
- High speed vibrations up to 25 m/s

#### FOR SPECIAL MEASUREMENT ENVIRONMENTS

The FIBER Series is a follow-up development of the NOVA Series in which the compact optical head is connected via fibre optics with the measuring instrument. Separate fibres for the measurement beam and the reflected signal ensure optimum signal quality.

Compact measuring heads make the system not only particularly suitable for measurements in a confined space but also simplify handling when the application requires a frequent repositioning of the head. Specially made heads are available for vacuum- or climatic chambers as well as for extreme environments with very high levels of background radiation.

# Technical Data

## Measured Quantities – Performance Parameters

Max. <sup>2</sup> Frequency	Max. <sup>2</sup> Velocity	Best Vel. <sup>1</sup> Resolution	Max. <sup>2,3</sup> Displacement	Best Disp. <sup>1a</sup> Resolution	Max. <sup>2,3</sup> Acceleration	Best Accel. <sup>1</sup> Resolution
24 MHz	25 m/s	1.7 nm s <sup>-1</sup> /√Hz	±1.225 m	0.05 pm /√ Hz	78.4 Mg	1.8μg /√Hz

<sup>1</sup> The Resolution is defined as the signal amplitude (rms) corresponding to a signal-to-noise ratio (SNR) of 0dB with 1 Hz spectral resolution at 50 % f<sub>max</sub> of smallest measurement range.

<sup>1a</sup> The Resolution is defined as the signal amplitude (rms) corresponding to a signal-to-noise ratio (SNR) of 0dB with 1 Hz spectral resolution.

<sup>2</sup> Actual specifications depend on the configured decoder.

<sup>3</sup> Optional available

## Measurement Specifications

Measured quantities	Velocity, displacement, acceleration
Frequency bandwidth <sup>2</sup>	0 Hz - 24 MHz
Max. velocity <sup>2</sup>	25 m/s
Velocity measurement ranges <sup>2</sup>	14
Signal processing	Digital (FPGA based)
Source impedance	50 Ohm
Analog signal output	3 × BNC, ±2 V - Velocity, displacement <sup>3</sup> , acceleration <sup>3</sup> , signal generator <sup>3</sup> - Data rate: 160 MSamples/s @ 16-bit
Digital Signal Output & PC-Interface	1 Gbit RJ45 Ethernet: - Data rate: 1 GBit (53.3 MSamples/s @ 16-bit) - Digital data acquisition- and analysis software <i>OptoGUI</i> - Digital remote control of device settings
External Trigger	Digital external trigger in/out via SMB
Filter	High-pass filter: off / 10 / 20 / 40 / 80 / 160 / 320 / 640 Hz 1.28 / 2.56 / 5 / 10 / 20 / 40 / 80 / 160 kHz (0.16 / 7 / 50 Hz) <sup>4</sup> Low-pass filter: off / 2.5 / 5 / 10 / 20 / 50 / 100 kHz Tracking filter: off / slow / fast

<sup>4</sup> For Sense Remote decoder

## Optical Specifications

Working distances	Variable working distance from 0 mm to >300 m
Laser wavelength	Measurement laser: 1550 nm, Target laser: 510-530 nm
Laser safety class	Measurement laser: output power: <10 mW, class 1 Target laser: output power: <1 mW, class 2
Optics	Auto-, remote-, and manual focussing

## General Device Specifications

User interface output	Color screen 3.5" + 20 segment LED bargraph
User interface input	Touch screen, knobs with push-button, key switch (power)
Operating temperature	0 to +40°C
Dimensions	Length × width × height (excluding handle and lens): 380 × 180 × 148 mm
Weight	8 kg + objective lens
Power supply	110 - 240 V AC (50-60Hz) or 12 V DC
Portable Operation	Possible
Portable power supply	12 V DC portable charger <sup>3</sup>
Integrated signal generator <sup>3</sup>	- Produce various preset functions (sin, chirp, gaussian, ...) - Import of arbitrary functions and audio wave-files

## Model Options - Decoders<sup>5,6</sup>

<sup>5</sup>For details see decoder data-sheets. <sup>6</sup>Variations from displayed models available on request.

### Overview Model Options and Characteristics of the default Velocity Decoder<sup>7</sup>

Model (Decoder)	Description	Measuring Ranges <sup>5</sup>	Max. Velocity	Frequency Bandwidth
Start (D-VD-0N)	Entry model.	7	2.5 m/s	0 Hz – 100 kHz
Basis (D-VD-1N)	Versatile model with high resolution <sup>8</sup>	8	5 m/s	0 Hz – 500 kHz
Sense (D-VD-2N)	Smallest measurement range ± 2.45 mm/s and highest resolution <sup>9</sup>	11	5 m/s	0 Hz – 1 MHz
Sense Remote (D-VD-2N-R)	Sense features + extra low disp.-HPF 0.16 / 7 / 50 Hz (measure building vibrations, etc.).	11	5 m/s	0 Hz – 25 kHz
Sense Speed (D-VD-2N-12)	Sense features + additional measurement range at ± 12 m/s.	12	12 m/s	0 Hz – 1 MHz
High Speed (D-VD-3N)	Supports measurements up to highest velocities.	11	25 m/s	0 Hz – 2.5 MHz
High Frequency (D-VD-4N)	Supports measurements up to highest frequencies.	9	12 m/s	0 Hz – 10 MHz
Master (D-VD-5N)	The all-rounder: Includes all Sense, High Speed, and High Frequency features.	14	25 m/s	0 Hz – 10 MHz
Master+ (D-VD-5N-24)	Includes all Master features and has an additional super-high frequency upgrade	14	25 m/s	0 Hz – 24 MHz <sup>10</sup>

<sup>7</sup> All models feature by default a velocity decoder and optionally displacement and acceleration decoders

<sup>8</sup> Best velocity res.: 12 nm s<sup>-1</sup> / √Hz.

<sup>9</sup> Best velocity res.: 1.7 nm s<sup>-1</sup> / √Hz.

<sup>10</sup> Velocity limited to 1 m/s at frequencies above 10 MHz.

### Characteristics of the optional Displacement Decoder<sup>7</sup>

Decoder	Required Vel-Decoder	Number Measuring Ranges <sup>5</sup>	Smallest Range <sup>11</sup>	Largest Range	Frequency Bandwidth
D-DD-0N	D-VD-0N	19	± 122.5 nm	± 122.5 mm	0 Hz – 100 kHz
D-DD-1N	D-VD-1N	19	± 122.5 nm	± 122.5 mm	0 Hz – 500 kHz
D-DD-2N	D-VD-2N	19	± 122.5 nm	± 122.5 mm	0 Hz – 1 MHz
D-DD-2N-R	D-VD-2N-R	19	± 122.5 nm	± 1.225 m	0 Hz – 25 kHz
D-DD-2N-12	D-VD-2N-12	19	± 122.5 nm	± 122.5 mm	0 Hz – 1 MHz
D-DD-3N	D-VD-3N	19	± 122.5 nm	± 122.5 mm	0 Hz – 2.5 MHz
D-DD-4N	D-VD-4N	19	± 122.5 nm	± 122.5 mm	0 Hz – 10 MHz
D-DD-5N	D-VD-5N	19	± 122.5 nm	± 122.5 mm	0 Hz – 10 MHz
D-DD-5N-24	D-VD-5N-24	19	± 122.5 nm	± 122.5 mm	0 Hz – 24 MHz <sup>10</sup>

<sup>11</sup> Best displacement resolution: 0.05 pm.

### Characteristics of the optional Acceleration Decoder<sup>7</sup>

Decoder	Required Vel-Decoder	Number Measuring Ranges <sup>5</sup>	Smallest Range <sup>12</sup>	Largest Range	Frequency Bandwidth
D-AD-0N	D-VD-0N	7	± 392 g	± 1.6 Mg	0 Hz – 100 kHz
D-AD-1N	D-VD-1N	8	± 392 g	± 1.6 Mg	0 Hz – 500 kHz
D-AD-2N	D-VD-2N	11	± 3.9 g	± 3.2 Mg	0 Hz – 1 MHz
D-AD-2N-R	D-VD-2N-R	11	± 3.9 g	± 80 kg	0 Hz – 25 kHz
D-AD-2N-12	D-VD-2N-12	12	± 3.9 g	± 7.6 Mg	0 Hz – 1 MHz
D-AD-3N	D-VD-3N	11	± 392 g	± 39.2 Mg	0 Hz – 2.5 MHz
D-AD-4N	D-VD-4N	9	± 392 g	± 76.8 Mg	0 Hz – 10 MHz
D-AD-5N	D-VD-5N	14	± 3.9 g	± 78.4 Mg	0 Hz – 10 MHz
D-AD-5N-24	D-VD-5N-24	14	± 3.9 g	± 78.4 Mg	0 Hz – 24 MHz <sup>13</sup>

<sup>12</sup> Best acceleration resolution: 1.8µg / √Hz.

<sup>13</sup> Acceleration limited to 15.3 Mg at frequencies above 10 MHz.

## Set up Dual Fiber Vibrometer

### Fiber Head — Vibrometer — Output

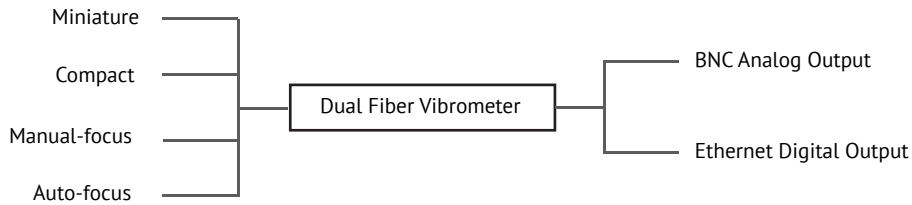

#### ■ Miniature Fiber Head with camera:

- Fix Working Distance: O-FF-MH-F
- Dimension (D x L): 11 x 52 mm  
Fix working distances: 4, 9, or 16 mm  
Inspection camera: resolution 640 x 480 pixel



#### ■ Compact Fiber Head:

- Collimated lens: O-C-CH-F
- Fix Working Distance: O-FF-CH-F  
Fix working distances: 27, 37, 64, 89, 139 or 189 mm  
Dimension: 89 L x 43.9 B x 95 H mm  
Weight: 0.5 kg

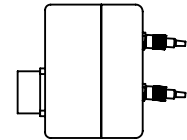

#### ■ Manual focus Fiber Head:

Manual focused lens with variable working distance

- Short-Range: O-MF-SR-F  
Working distance: 15 mm - 5 m  
Min. spotsize: 27  $\mu\text{m}$  at 15 mm
- Mid-Range: O-MF-MR-F  
Working distance: 269 mm - 10 m  
Min. spotsize: 67  $\mu\text{m}$  at 269 mm  
Dimension: 157 L x 43.9 B x 95 H mm  
Weight: 1.2 kg

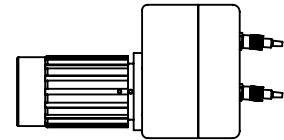

#### ■ Autofocus Fiber Head:

Auto-focused lens with variable working distance:

- Mid-Range: O-AF-MR-F  
Working distance: 132 mm - 10 m  
Min. spotsize: 42  $\mu\text{m}$  at 132 mm  
Dimension: 175.5 L x 43.9 B x 95 H mm  
Weight: 0.8 kg
- LR-Range: O-AF-LR-F  
Working distance: 447 mm - 100 m  
Min. spotsize: 72  $\mu\text{m}$  at 447 mm  
Dimension: 221 L x 43.9 B x 95 H mm  
Weight: 0.9 kg

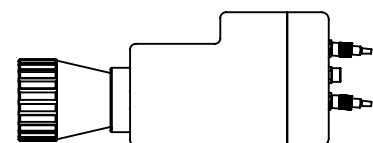
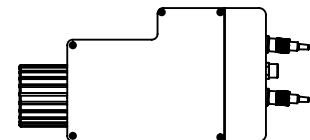

## Multiplex many fiber heads using a fiber switch

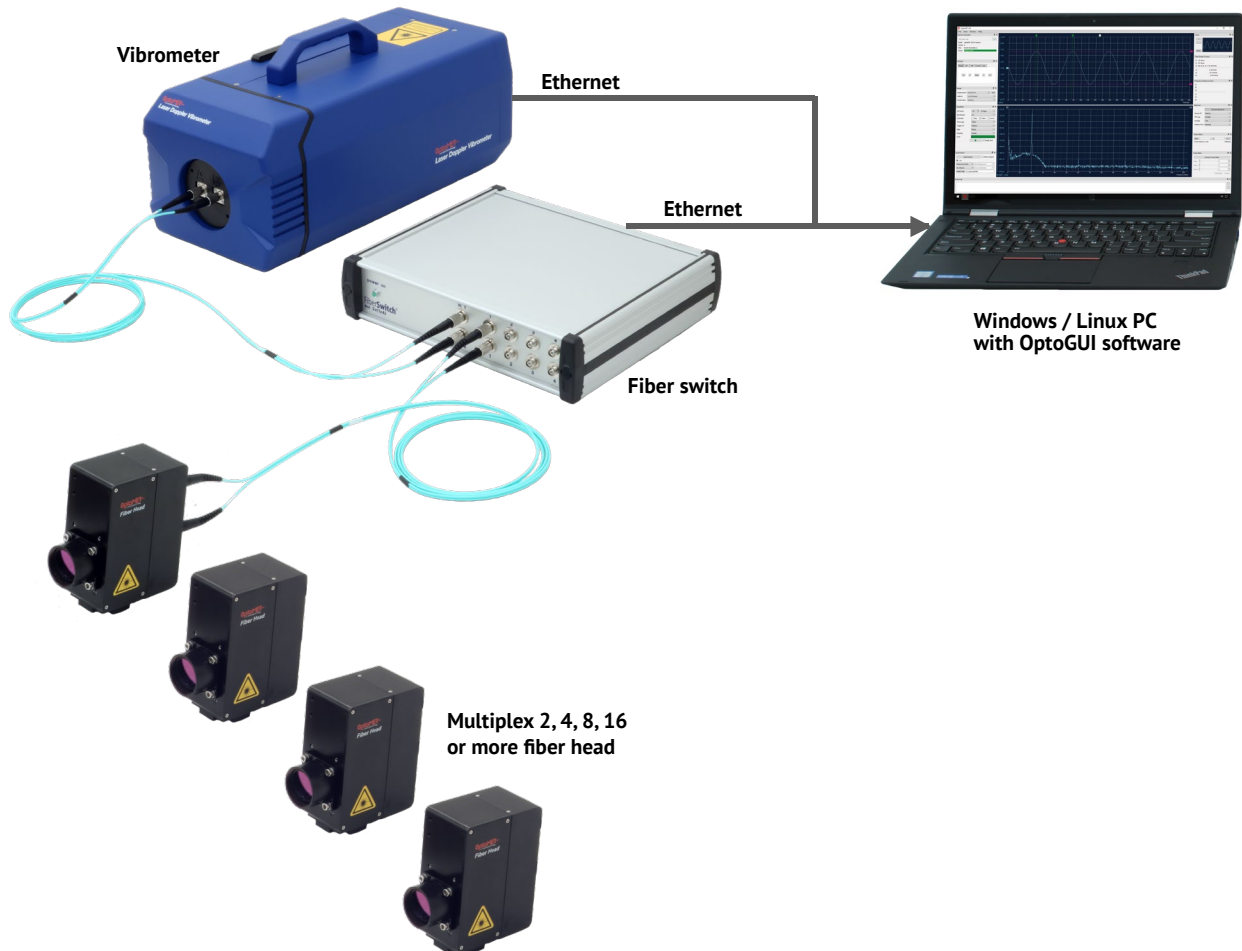

### Fiber switch technical data:

Switching times	2 ms
Guaranteed lifetime	> 100 Mio cycles
Switching frequency	< 50 Hz
Number of channels	2, 4, 8 or 16; other channel counts on request
Electrical interface	Ethernet, USB, RS232, TTL, I2C
Operating temperature	0 ... 60°C
Operating voltage	integrated power supply 110 -250V

### Remote control:

Auto- or manual switching	via Ethernet / OptoGUI software
---------------------------	---------------------------------

**Dimension of the Vibrometer:**

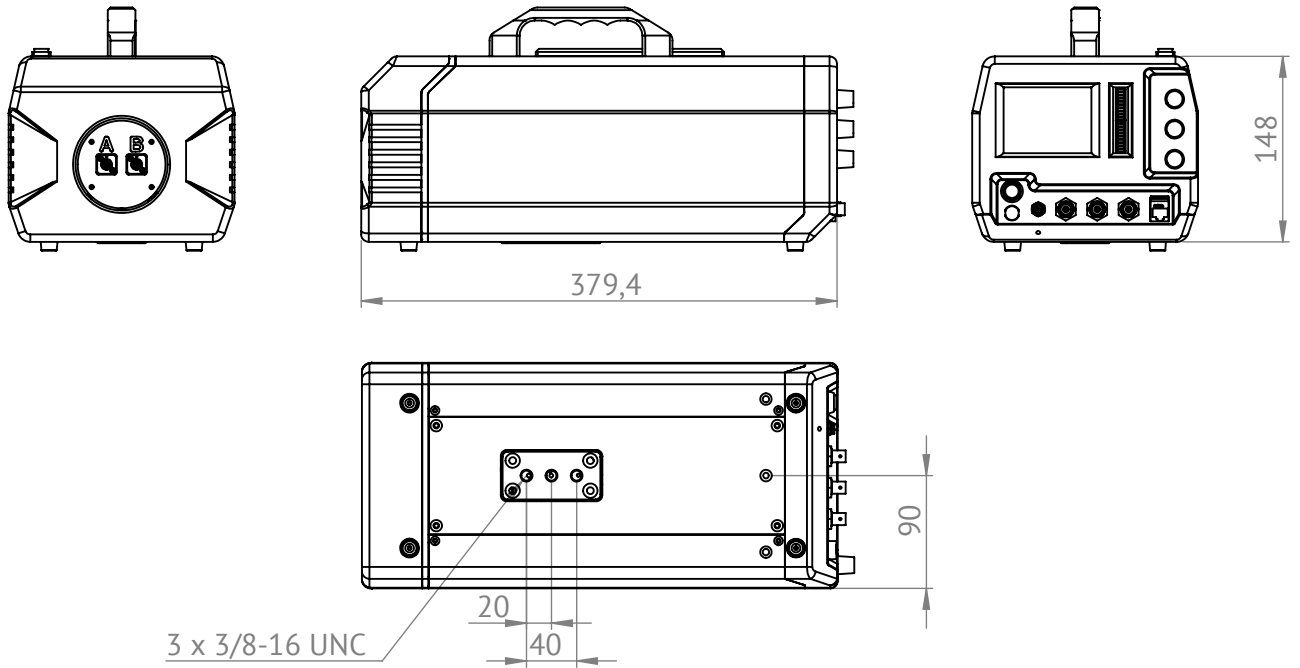

**Dimension of the autofocus Fiber Head without objective lens:**

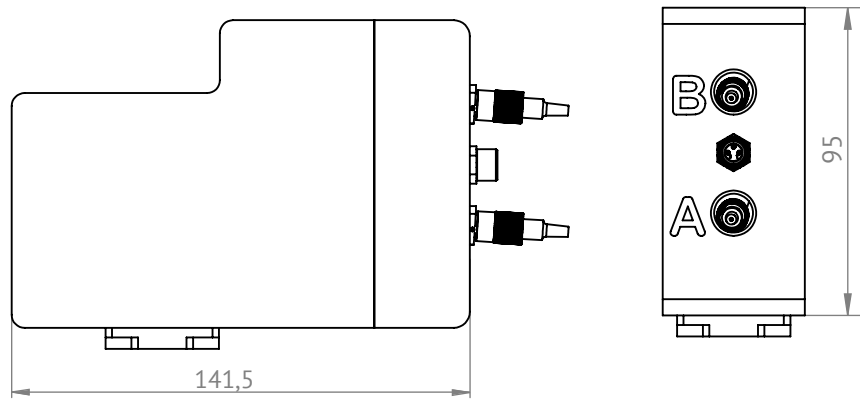

**Mounting plate for tripod**

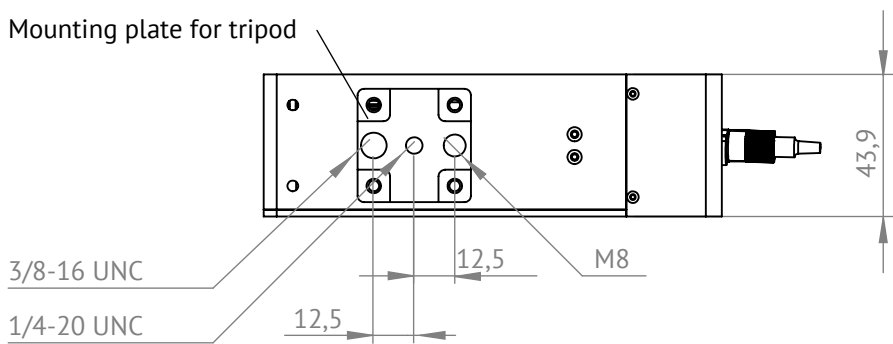

### Autofocus lenses technical data

Specification	O-AF-MR-F Mid-Range Autofocus 132 mm ... 10 m*	O-AF-LR-F Long-Range Autofocus 447 mm ... 100 m*
Focal length (mm)	50	100
Min. stand-off distance (mm)*	132	447
Spot size in $\mu\text{m}$ at:		
132 mm	42	
447 mm		72

### Dimension of the manual Fiber Head without objective lens:

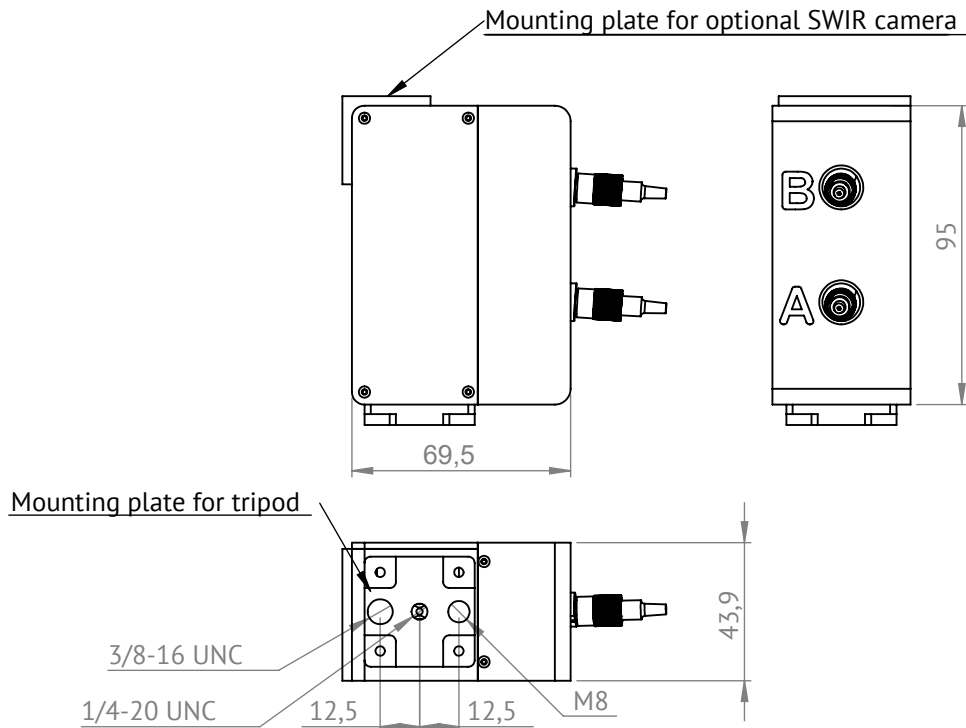

### Manual- and Fix lenses technical data

Specification	O-C-CH-F collimated	O-FF-CH-F fixed working distance	O-MF-SR-F Short Range manual focus 15 mm ... 5 m*	O-MF-MR-F Mid Range manual focus 269 mm ... 10 m*
Focal length (mm)	-	40 / 50 / 75 / 100 / 150 / 200	25	50
Min. stand-off distance (mm)*	0	27 / 37 / 64 / 89 / 139 / 189	15	269
Spot size in $\mu\text{m}$ at:	1400			
15 mm			27	
25 mm		25		
37 mm		29		
64 mm		43		
89 mm		61		
139 mm		90		
189 mm		118		
269 mm				67

\* Measured from the front of the fiber head



## Accessories

<sup>S</sup> Standard included, <sup>O</sup> Optional available

	<p><b>Transport Case for Single Point Vibrometer</b> Stable and waterproof <i>Peli</i> case for safe keeping and transport of vibrometer. External dimension (L x B x H): 61.9 x 49.2 x 22.3 cm</p>	S
	<p><b>Transport Case for Manual Focus Fiber Head</b> Safely stow your manual focus fiber head in a high quality <i>Peli</i> case.</p>	S
	<p><b>Transport Case for Autofocus Fiber Head</b> Safely stow your autofocus fiber head in a high quality <i>Peli</i> case..</p>	S
	<p><b>Transport Bag</b> Compact und light transport bag for outdoor measurements or transport as carry-on baggage in an plane.</p>	O
	<p><b>IR-Detector Card</b> Transforming the not-visible infrared light into a spot of visible light.</p>	S
	<p><b>Mobile Battery</b> Portable battery charger, external battery power bank. For powering the vibrometer when performing outdoor measurements.</p>	O
	<p><b>Tripod with Fluid Head</b> Precisely align your vibrometer with high quality tripods by <i>Manfrotto</i>.</p>	O
	<p><b>Positioning Stage</b> Precisely align your Fiber measurement head. <i>Manfrotto</i>.</p>	O
<h2>Software</h2>		
	<p><b>OptoGUI Analysis Software</b> Software for data acquisition, analysis and remote control. Live animation of measured time and frequency data.</p>	O

## OptoGUI software includes

Remote control	Remotely control all vibrometer settings via ethernet.	<b>S</b>
Read-out	Read out data via ethernet with up to 80 MS/s	<b>S</b>
Time data	Live animation of measured vel. /disp. /accel. data	<b>S</b>
Export data	Export time data as .csv, .h5, .wav or .mat files	<b>S</b>
Fourier-Transformation	-Real-Time Fast Fourier Transformation -up to 536 Mio. FFT lines	<b>S</b>
Peak identification	Automatically identify signal peaks in the frequency spectrum	<b>S</b>
Spectrogram	Show a live Spectrogram of the FFTs of the ongoing measurements	<b>S</b>
Fourier boundaries	Limit live FFT-calculation to certain time ranges of the time data	<b>S</b>
Signal trigger	Trigger your measurement with the vel., disp., or accel. signal	<b>S</b>
External trigger	Trigger your measurement with an external TTL signal (3.3 V)	<b>O</b>
Multiple traces	Record and recall multiple traces of the vel./disp./accel. time data	<b>S</b>
Arbitrary signal generator	Import file formats: .csv ASCII- or .wav audio files Pre-defined signals: sin, rectangle, chirp, random, ...	<b>S</b>

## Maintenance Specials

### Warranty

Warranty	12 months	<b>S</b>
Warranty extension	Extension of standard warranty to 24 months	<b>O</b>

### Software Updates

Software maintenance	Free software updates within warranty period	<b>S</b>
Extended maintenance	Additional extension of software updates by 12+ months	<b>O</b>

### Hardware Maintenance

Hardware Maintenance	Free hardware maintenance within warranty period	<b>S</b>
Extended maintenance	Additional extension of hardware maintenance by 12+ months	<b>O</b>
Recalibration & cleaning	Check, cleaning & realignment of optical parts, check of laser output power, perform factory calibration	<b>O</b>

## Laser product label

DO NOT STARE INTO BEAM Class 2 Laser Product

Laser CLASS 1: invisible,  $\lambda = 1550$  nm, output power: < 10 mW

Laser CLASS 2: visible, green laser beam,  $\lambda = 510-530$  nm,  
output power: < 1 mW

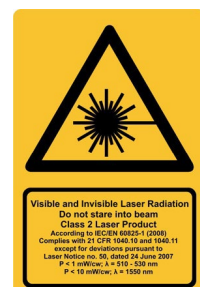

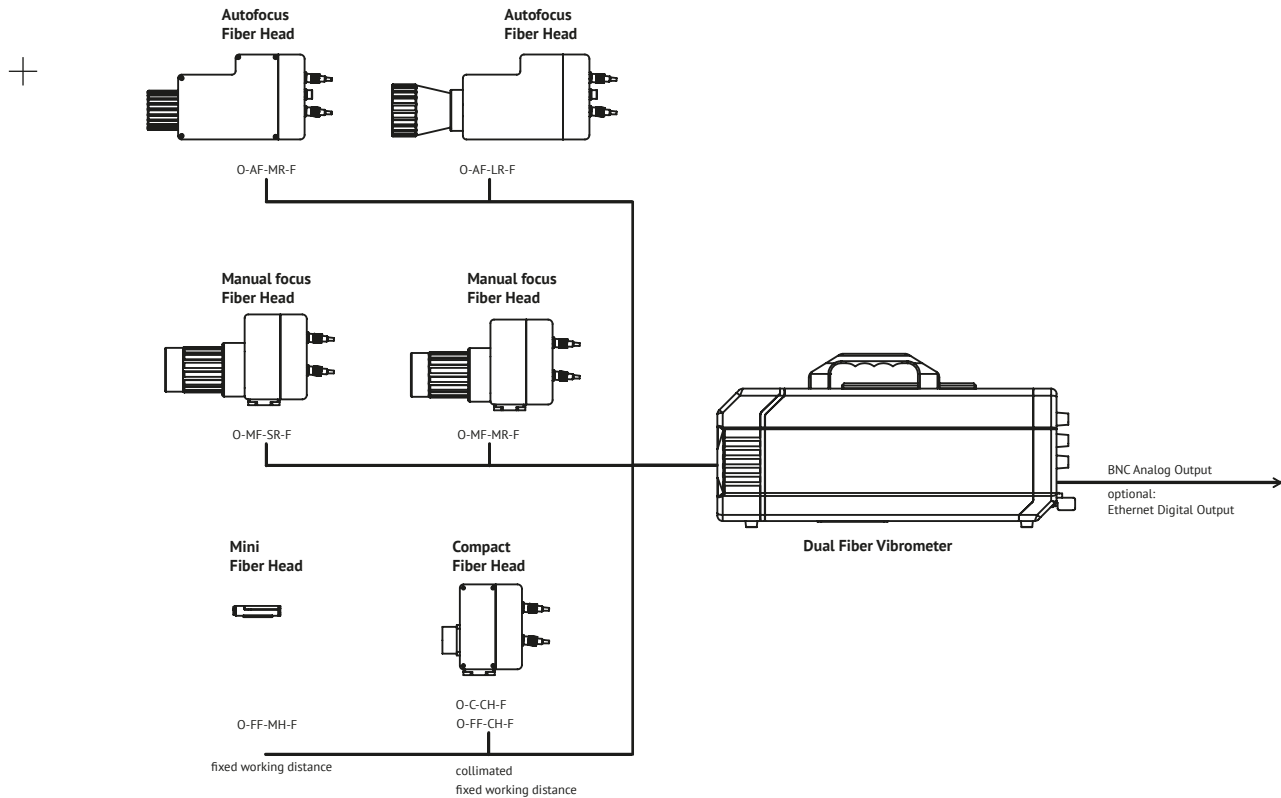

CONTACT US